

The Brillopak P160 Unipick provides high-speed, accurate but gentle packing of tray seal, flow wrap and VFFS products into trays, cases and boxes.

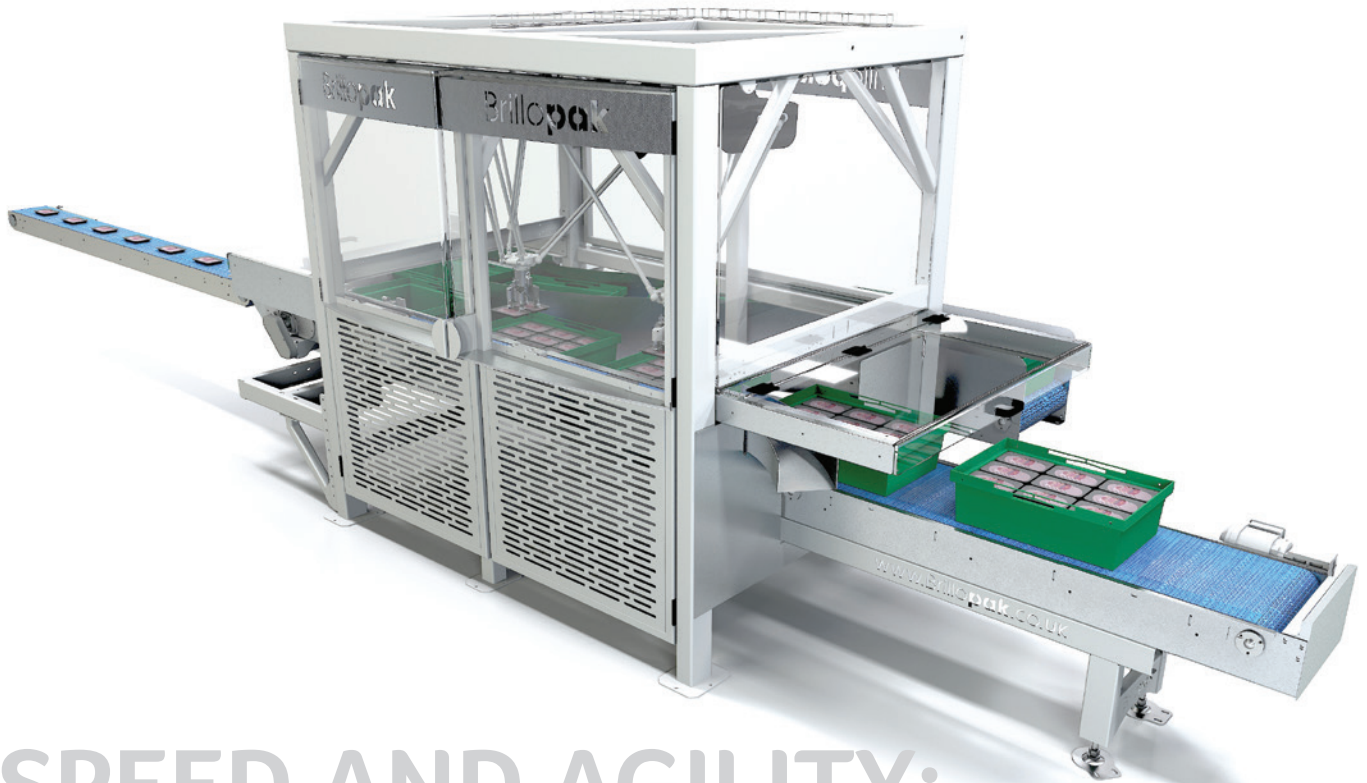

## SPEED AND AGILITY:

OVER 100 PACKS  
PER MINUTE

PRECISE PRODUCT  
PLACEMENT

MULTIPLE  
PRODUCTS AND  
LAYER PATTERNS

One machine, multiple products, multiple locations = EXCELLENT RETURN ON INVESTMENT.

Using high-speed robotics, the Brillopak P160 handles individual packs so efficiently that pre-collation is unnecessary. By picking single products the system offers complete flexibility over number of packs per layer and arrangement of packs in each layer.

Originally developed for fresh produce the system ensures no damage to product and enhanced presentation in the crate or case.

With specialist Brillopak robot heads each machine can handle multiple products.

### Additional Benefits:

- Consistency of operation. Use of integrated high-speed conveyor tracking using vision guidance where required to identify centre of gravity location of each product means products can arrive into the system in an inconsistent format without causing stops.
- Delicate handling: Due to single pick, products are placed into position individually.
- Simple to operate, manage and maintain.
- No complex collation requirement: Less to go wrong

## Technical Data

Suitable for:	Packing into trays, boxes, and cases.
Max. Pack weights:	2.5kg
Speed:	Over 100 packs per minute at regular intervals dependent on product type and robot configuration.
Build	Mild Steel or Stainless Steel frame. Touch points all stainless steel or food grade materials.
Dimensions:	3200mm x 1500mm
Robots	1-3 high speed Delta type robots with motion control and vision system dependent on application.
Robot end effectors	Brillopak specialist end effectors using multiple vacuum cups with independent generators or soft flexible grippers dependent on application.
Pneumatic supply	Compressed air at 6 bar min.
Geared drives:	Omron.
Control System	Omron NJ Series with integrated motion control, PLC, HMI and separate safety circuit (conforms to IEC61131-3 standard programming). Omron colour touchscreen with recipe control.
Electrical & Pneumatic Components:	Enclosure/Motor Specification: Minimum IP55 dust, splash proof.
ISO/DIN standard.	ISO/DIN standard.
Electrical:	3ph+N+E x 400/440 Vac +PE 50 Hz 16amp supply.
Control Circuit 24v DC.	Compressed air at 6 bar min.
CE Marking	CE marked.

## Dimensions

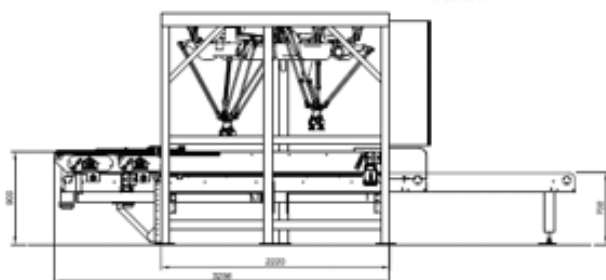
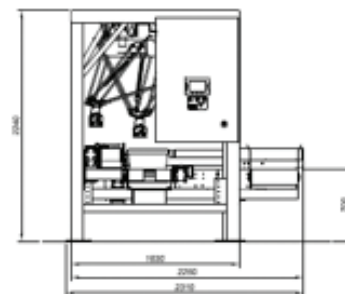
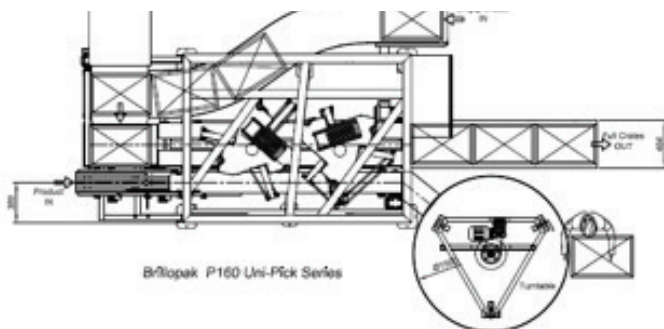

Integrates with:  
 Brillopak C250 Crate destacker  
 Brillopak C2 KT1200 palletiser

MADE IN BRITAIN 