

Transforms the efficiency of manual packing lines.



A MANUAL PACKING STATION THAT PUTS YOU BACK IN CONTROL OF PACK LINE SPEED:

**REDUCED
LABOUR COST**

**INCREASED
PRODUCT
THROUGHPUT**

**MINIMISED
QUALITY ISSUES**

A new way to reduce packing costs

Conventional manual packing lines encourage frequent short line stops and slower working. Operators are effectively in control of the line speed due to high levels of accumulation. This can lead to build-up of product, slower production speeds and damage or bruising to products.

Additional Benefits:

- Ergonomically designed for optimal performance
- Handles crates or cardboard trays
- Minimises health risks associated with repetitive working
- Tray infeed at rear or system minimises clutter along the line

The result is that more products can be packed with less people.

Technical Data

Suitable for:	600mm x 400mm rigid crates and cardboard trays, 300mm x 400mm crates and cardboard trays.
Build	Mild steel or Stainless steel frame with flexiglass inserts. Contact points stainless steel. Unit is on a single frame with frame inset to ensure closest proximity to product. Powered belt product conveyor with stainless steel sides and contact parts. Close pitch gravity roller conveyor for crates. Crate/case luffing conveyor.
Speed	7 off 600mm x 400mm crates per minute and 12 x 300mm x 400mm crates per minute.
Geared drives:	SEW Eurodrive.
Control System	Combined Proface controller/colour touchscreen HMI.
Pneumatic supply	Compressed air at 6 bar min.
Electrical & Pneumatic Components:	Enclosure/Motor Specification: Minimum IP55 dust, splash proof. ISO/DIN standard.
Electrical:	3ph+N+E x 400/440 Vac, 50 Hz, 16amp supply. Control Circuit 24v DC.
CE Marking	CE marked.

Layout Options

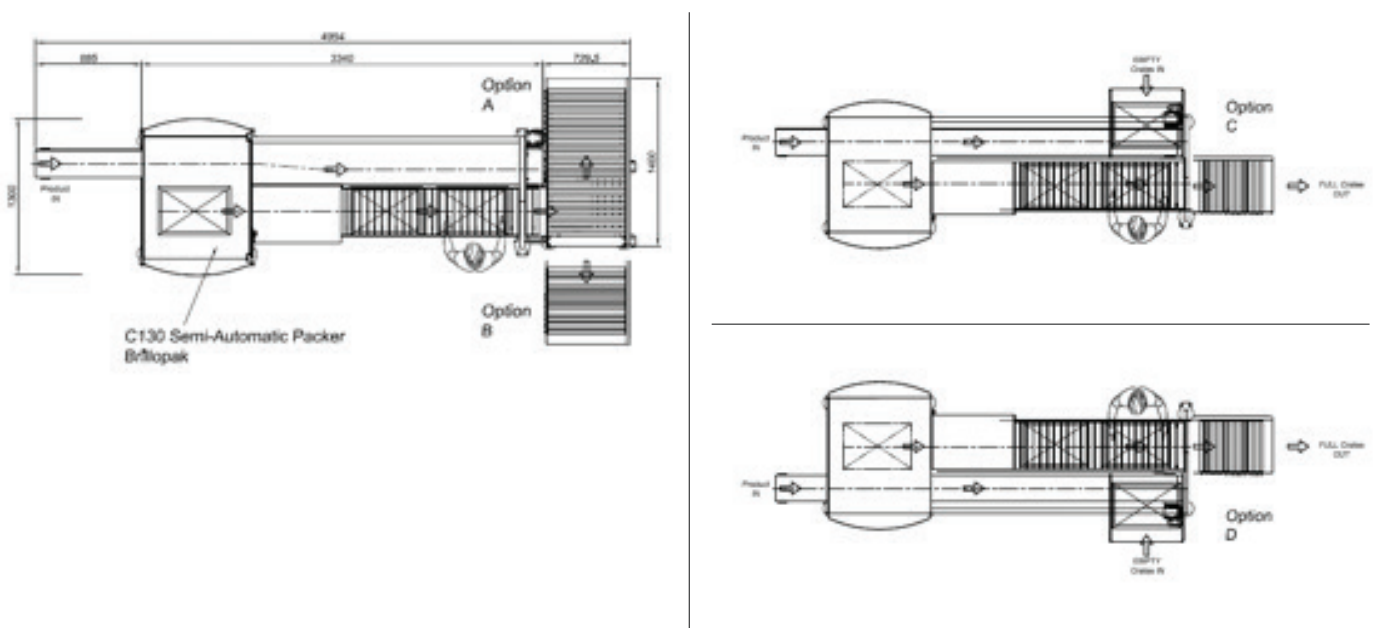

MADE IN BRITAIN 